

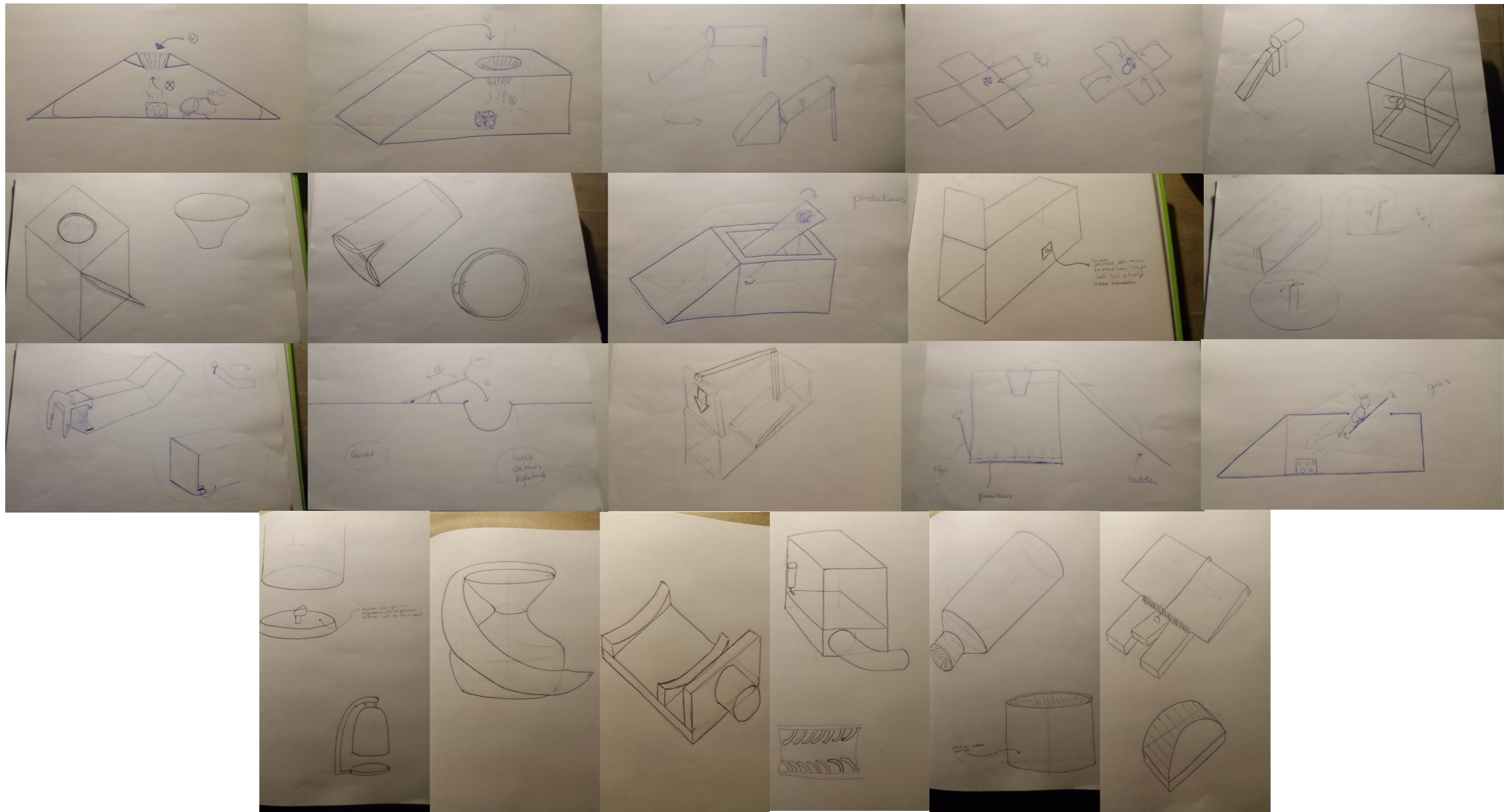









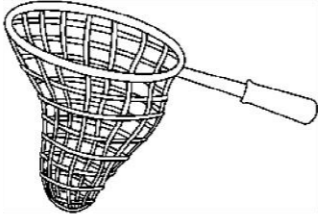





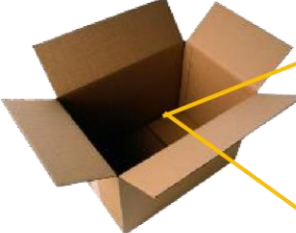









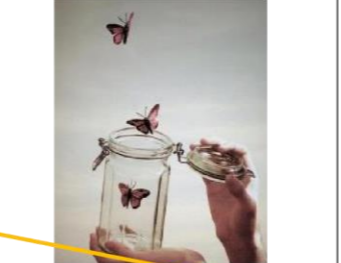
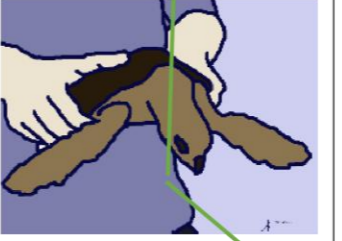
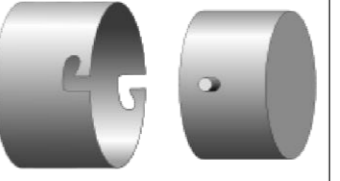

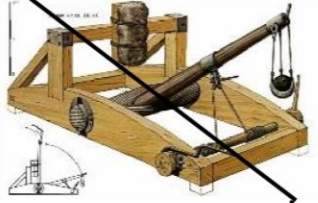



# Ontwerptraject



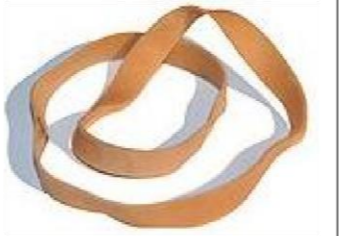















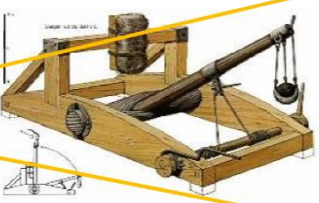



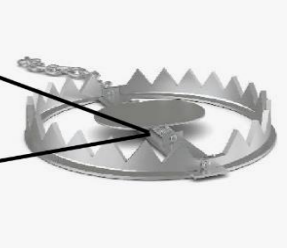





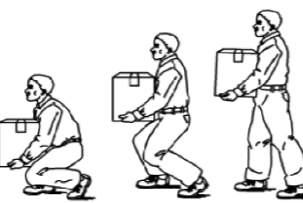
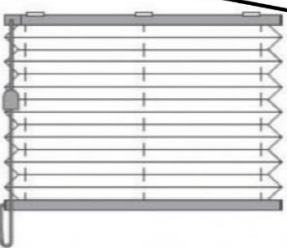

## 1. Schetsen

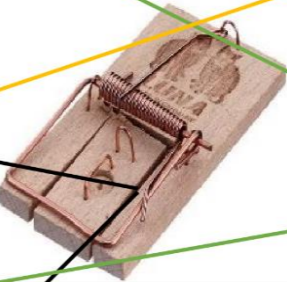
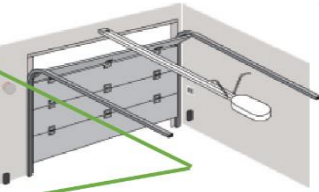

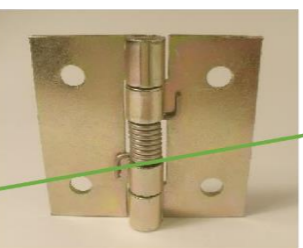



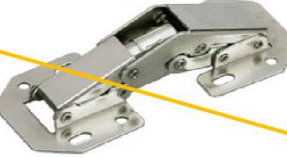



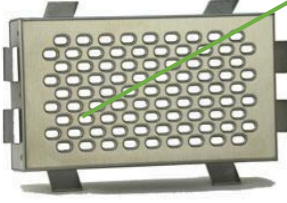

## 2. Morfologische overzicht

<p>Vangen muis</p>							
<p>Vasthouden muis</p>							
<p>Vrijlaten muis</p>							
<p>Op spanning zetten</p>							
<p>Bevestiging fles</p>							

3.

Stabiliteit							
Spanning vrijlaten							
Afsluiten fles							
Omhoog laten gaan fles							
Scharnieren							

Fles positioneren							
Muis in leven houden							

-  Concept 1 Daniël Mensinga
-  Concept 2 Iris Dirks
-  Concept 3 Chislain Huids

4. Concepten

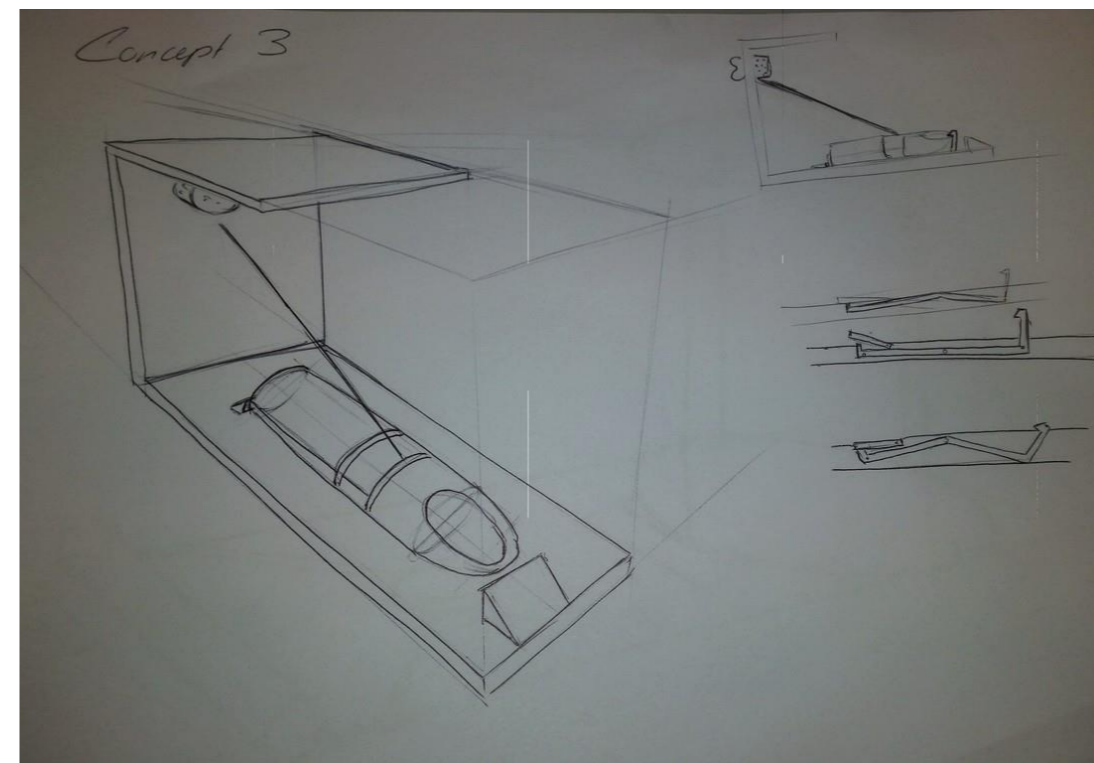
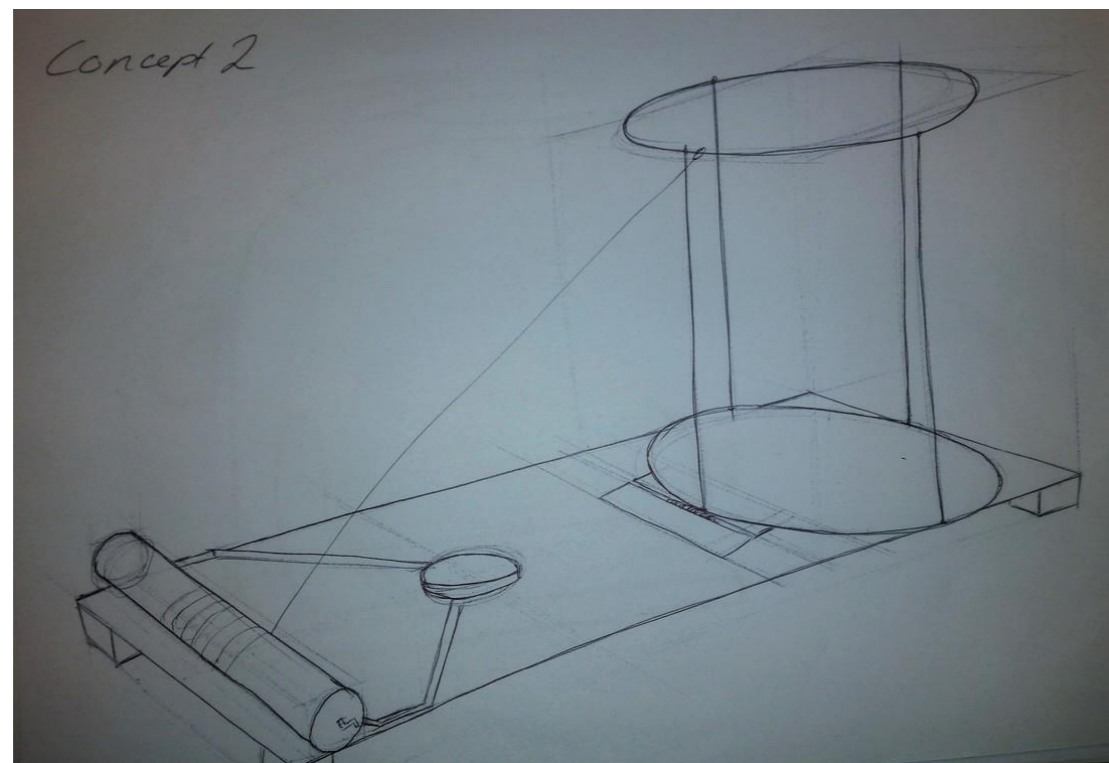
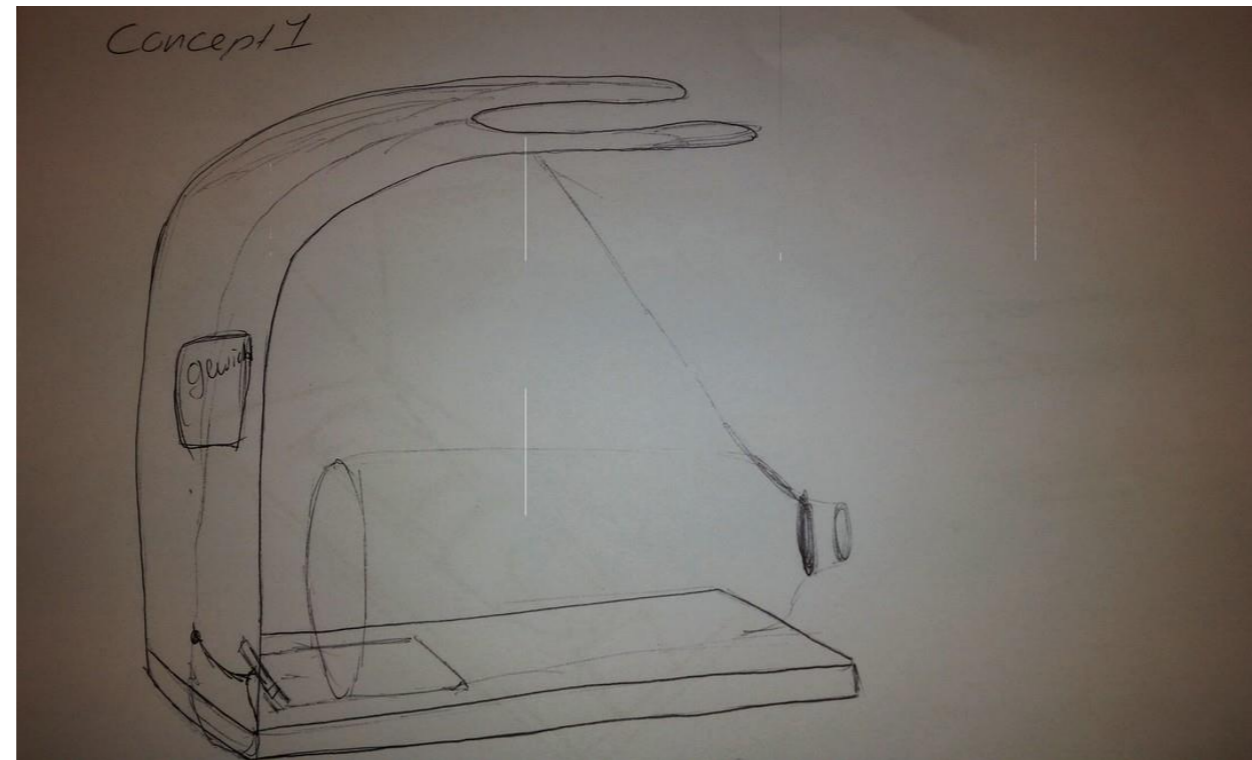

5. Kesselring methode

Functionele voorwaarden	Weegfactor (1-3)	Concept 1	Concept 2	Concept 3	4	5	Maximaal haalbaar totaal
Makkelijk in gebruik	3	(3) 9	(5) 15	(5) 15	X	X	15
Makkelijk hergebruiken	2	(3) 6	(5) 10	(5) 10	X	X	10
Goed schoon te maken	1	(5) 5	(5) 5	(5) 5	X	X	5
Makkelijk vrijlaten	2	(3) 6	(4) 8	(5) 10	X	X	10
Totaalscore		26	38	40	X	X	<del>40</del>
Maximum haalbare score							40
Percentage van maximum haalbare score		65%	95%	100%	X	X	

Fabricage voorwaarden	Weegfactor (1-3)	Concept 1	Concept 2	Concept 3	4	5	Maximaal haalbaar totaal
Goedkoop te maken	3	(2) 6	(5) 15	(4) 12	X	X	15
Snel te maken	3	(4) 12	(4) 12	(4) 12	X	X	15
Makkelijk in elkaar te zetten	2	(3) 6	(3) 6	(4) 8	X	X	10
		(...)	(...)	(...)	X	X	
Totaalscore		24	33	32	X	X	<del>40</del>
Maximum haalbare score							40
Percentage van maximum haalbare score		60%	82.5%	80%	X	X	

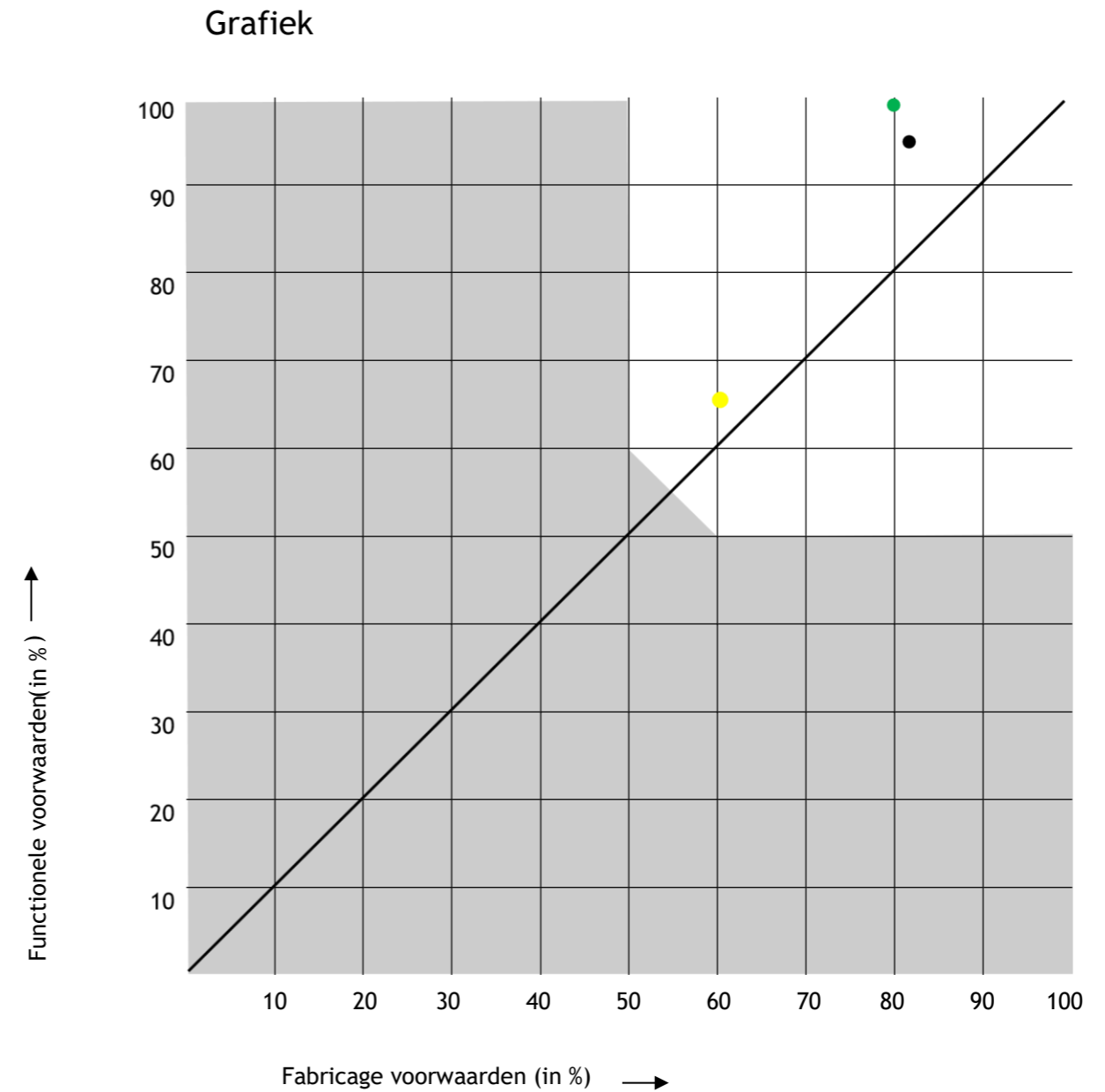

6. Conceptkeuze

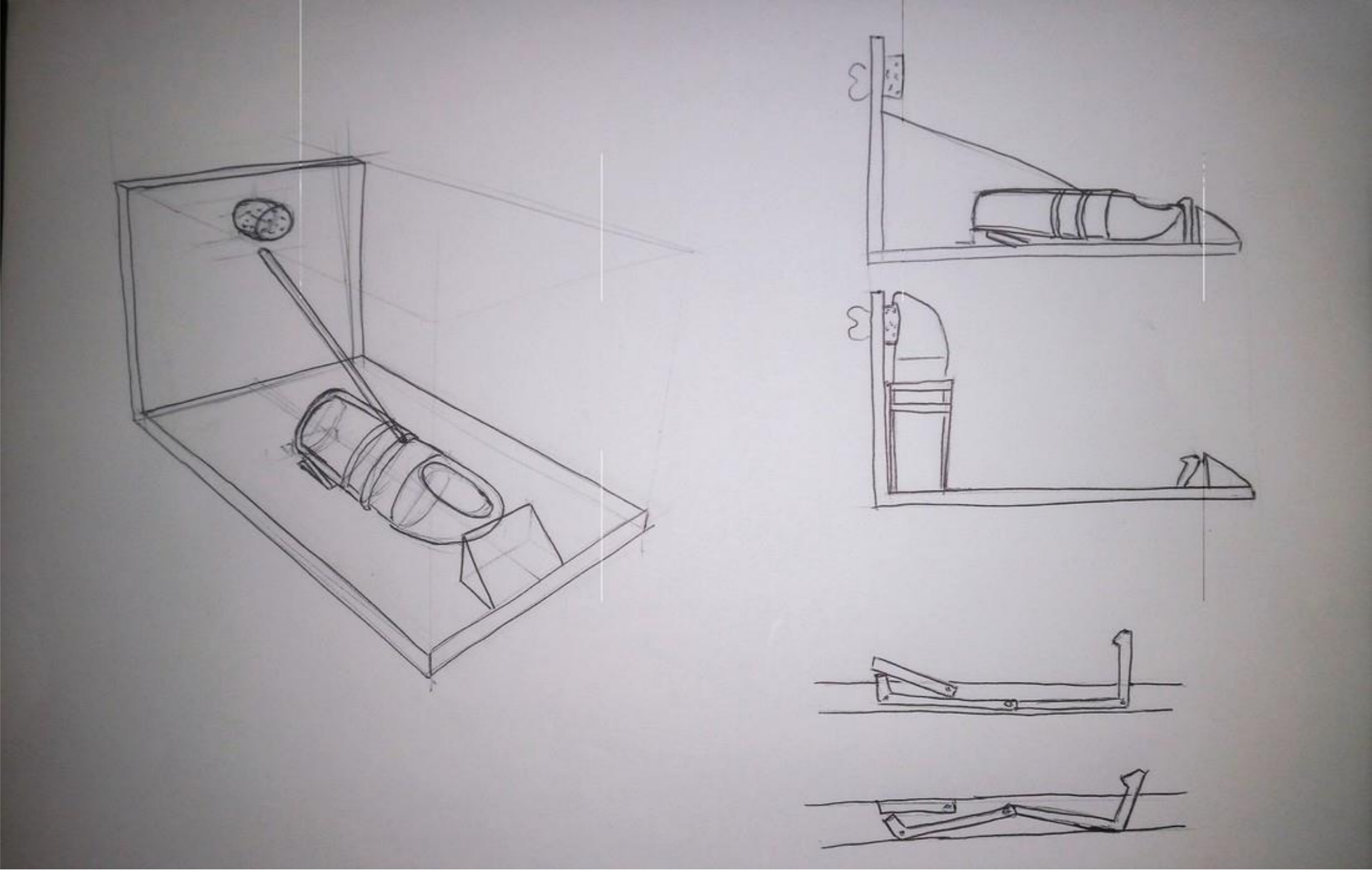

7. Spuugmodel

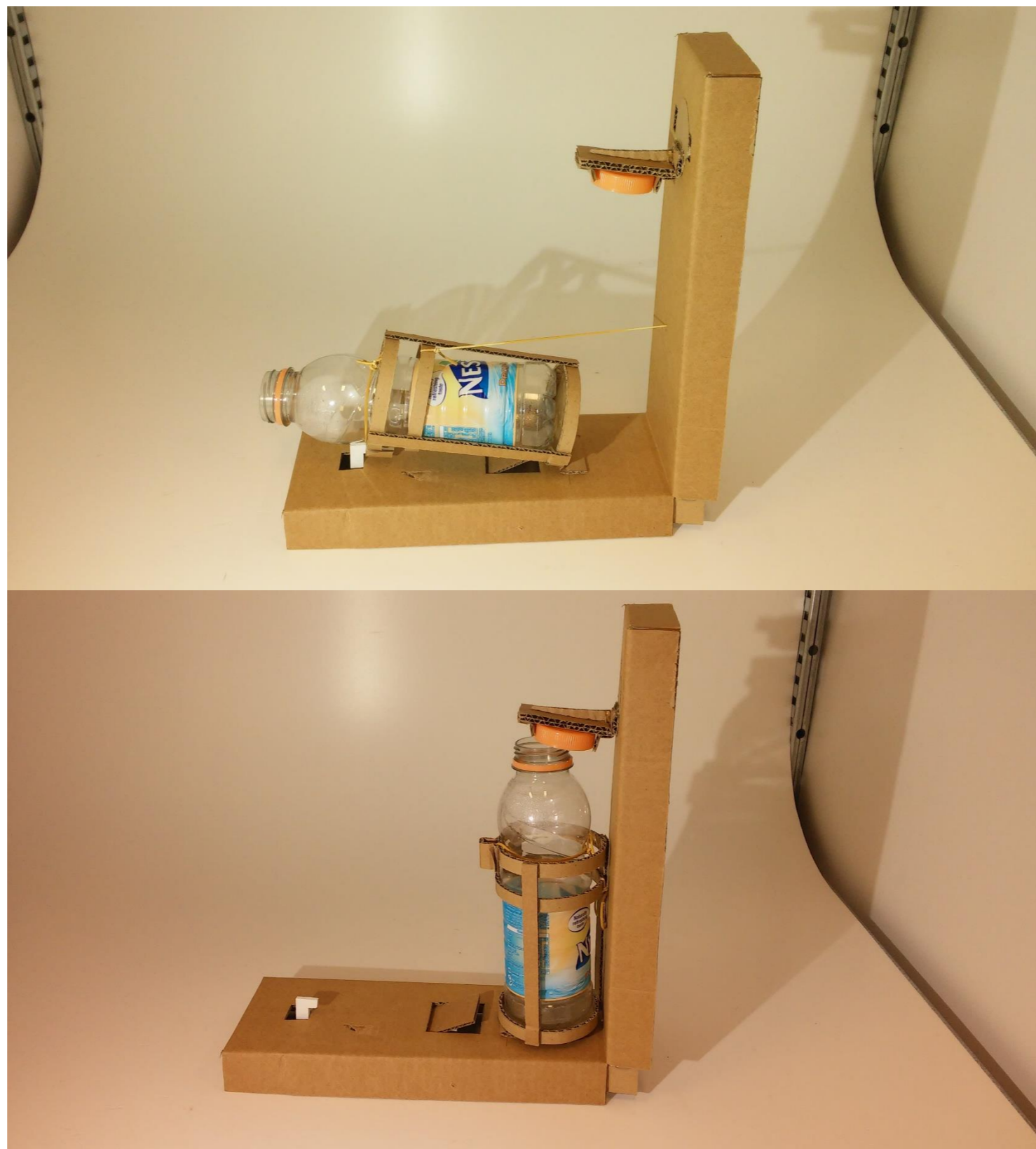



8. CAD-tekening

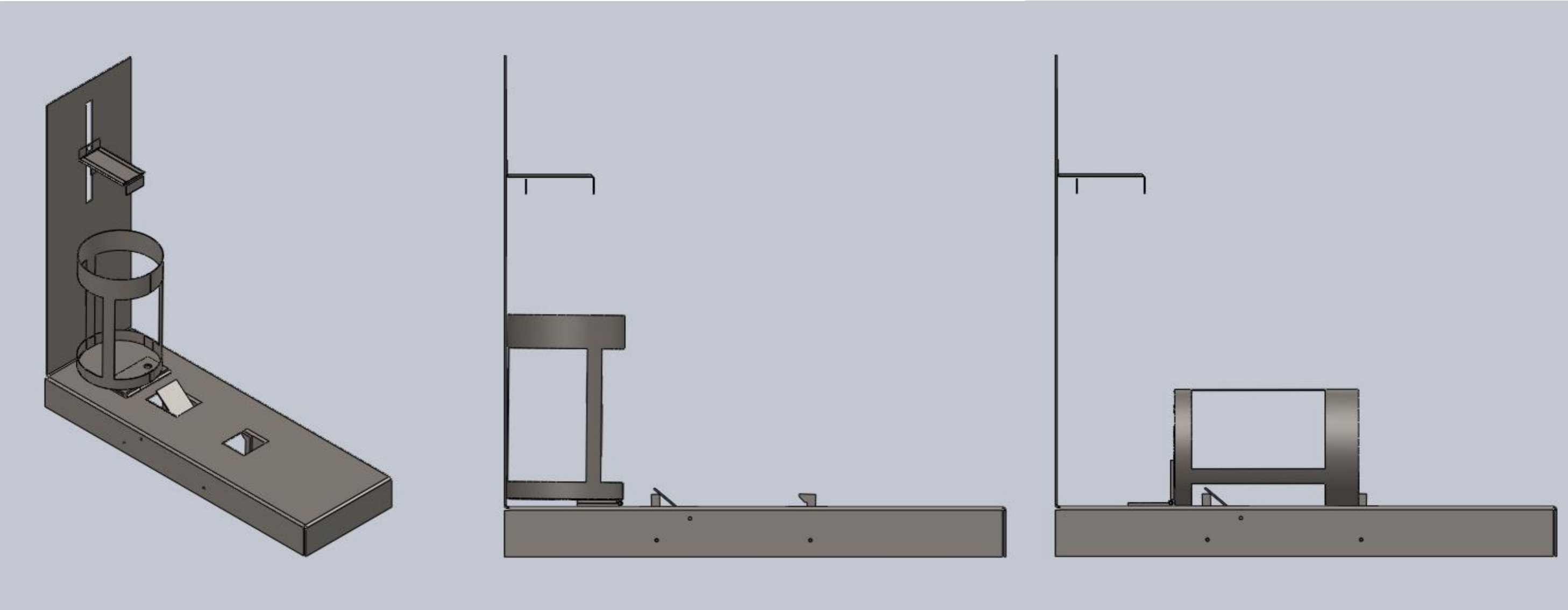

9. Werktekeningen

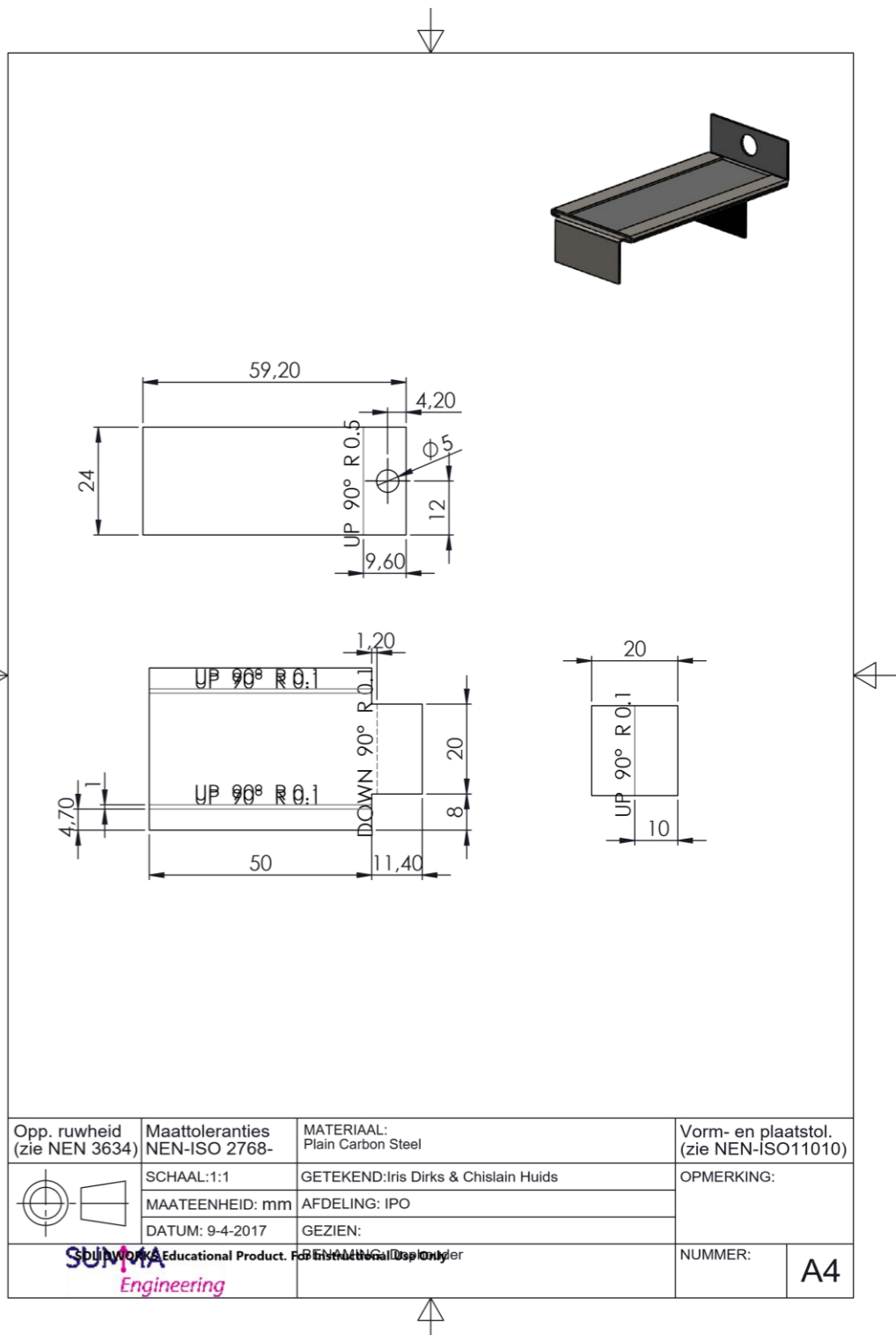
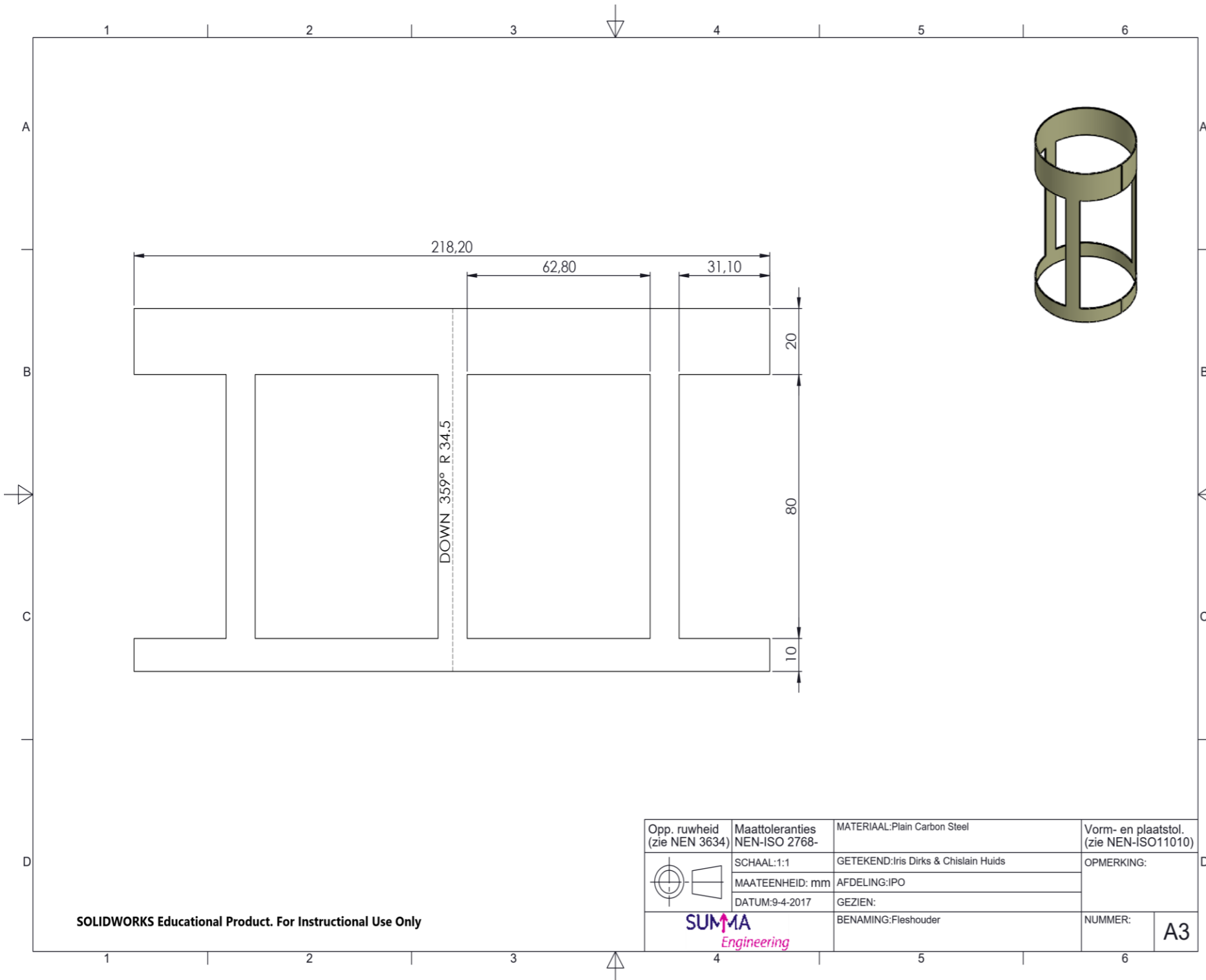

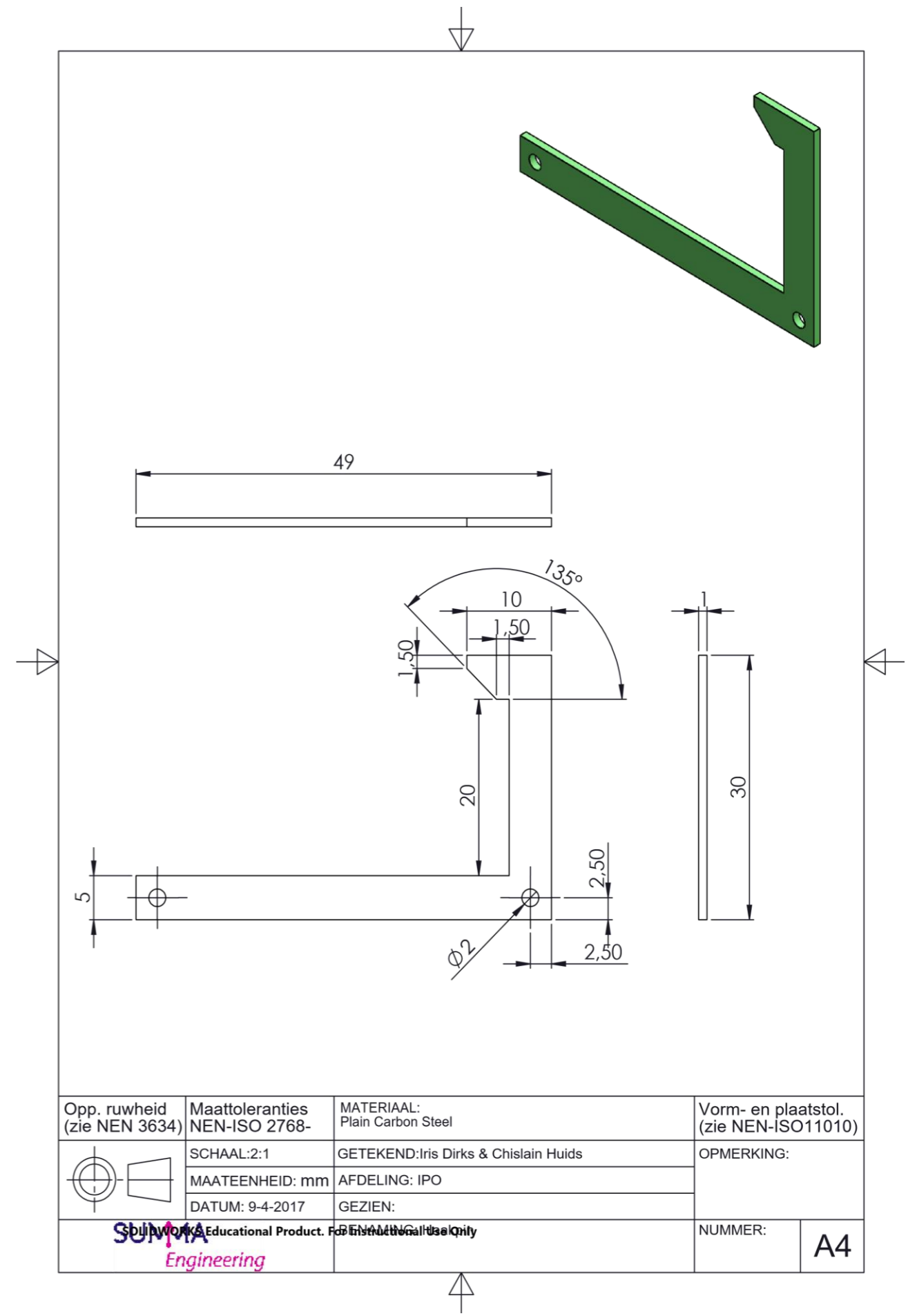
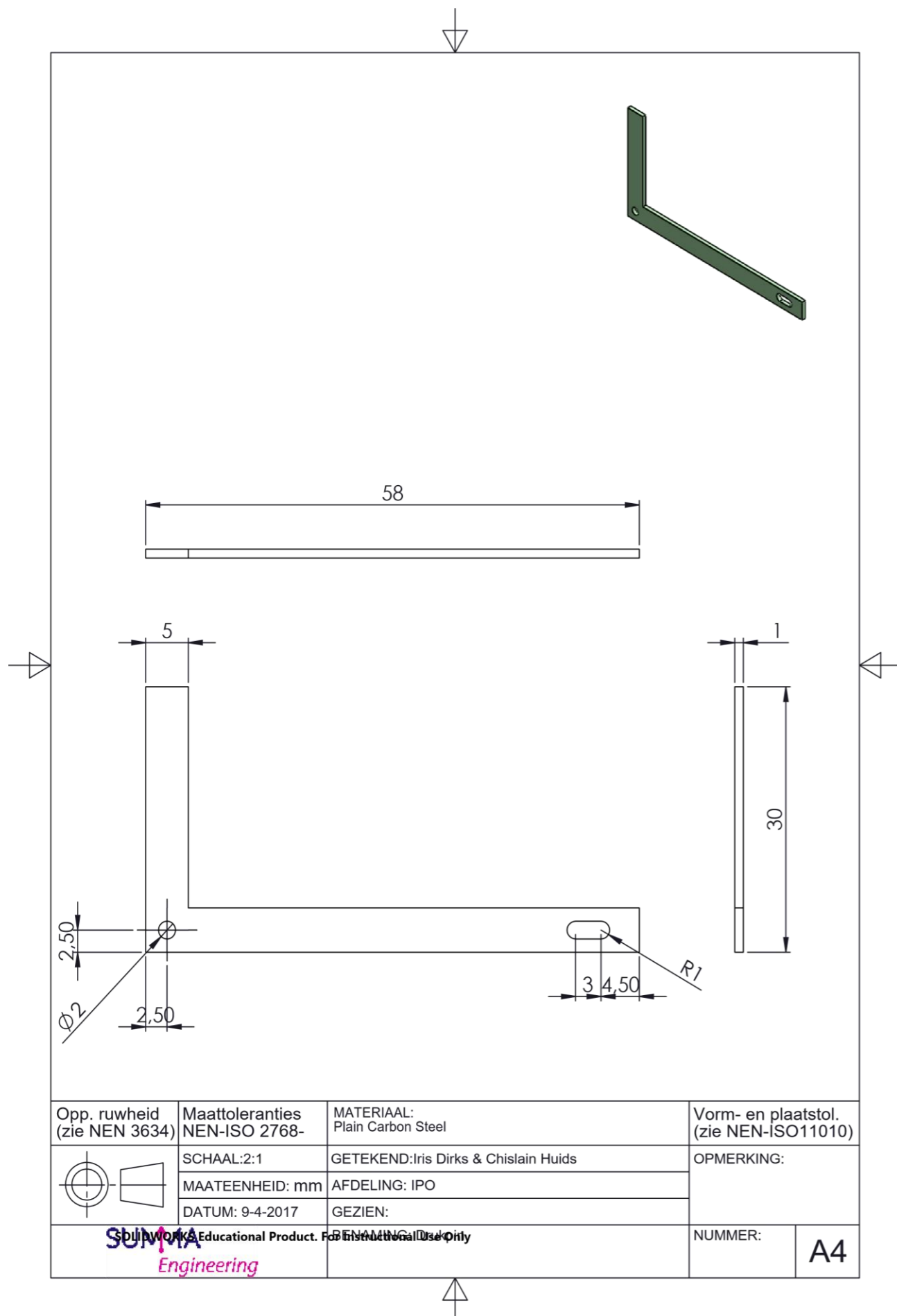

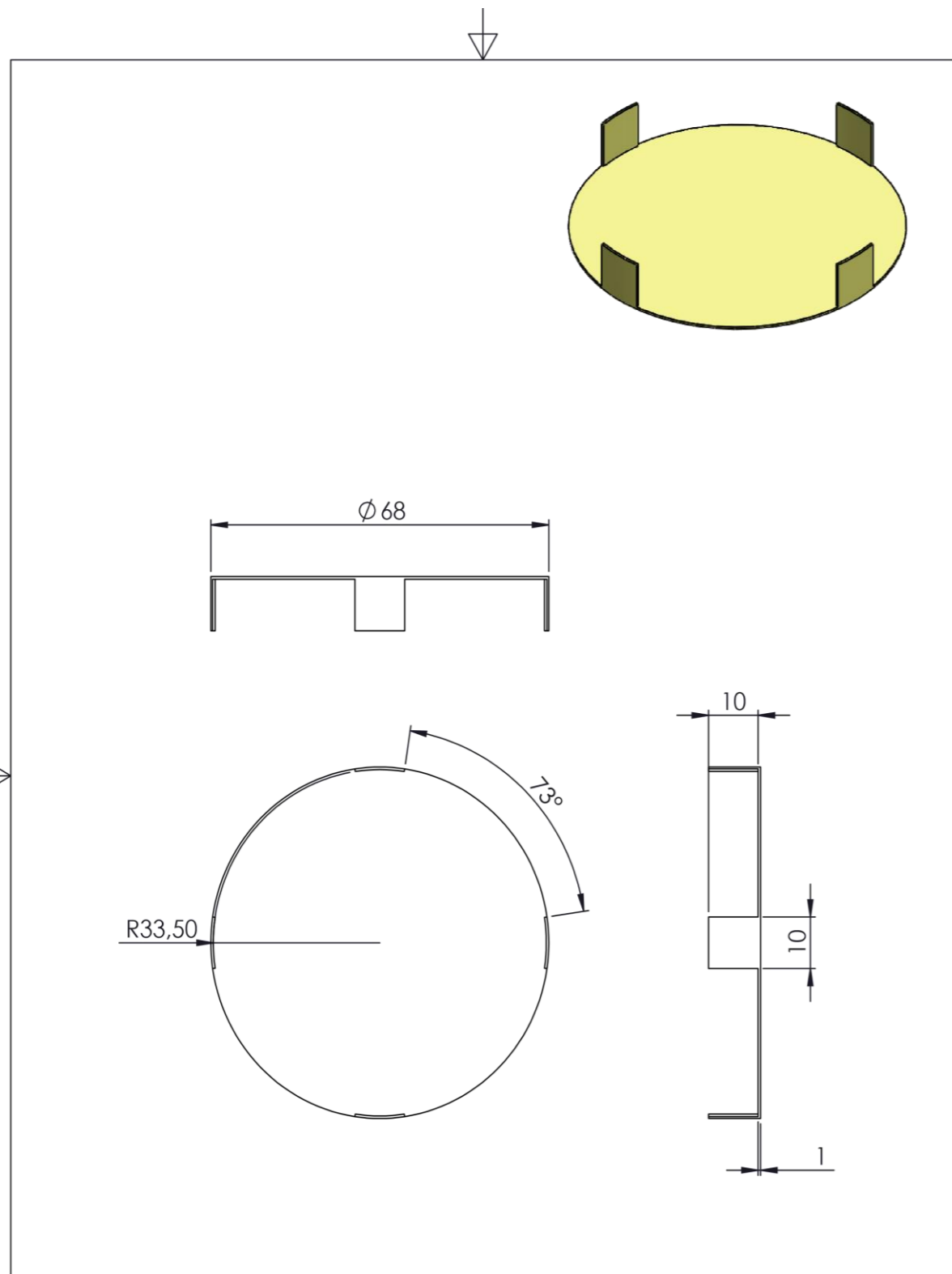

Opp. ruwheid (zie NEN 3634)	Maattoleranties NEN-ISO 2768-	MATERIAAL: Plain Carbon Steel	Vorm- en plaatstol. (zie NEN-ISO11010)
	SCHAAL: 1:1	GETEKEND: Iris Dirks & Chislain Huids	OPMERKING:
	MAATEENHEID: mm	AFDELING: IPO	
	DATUM: 9-4-2017	GEZIEN:	
			NUMMER: A4

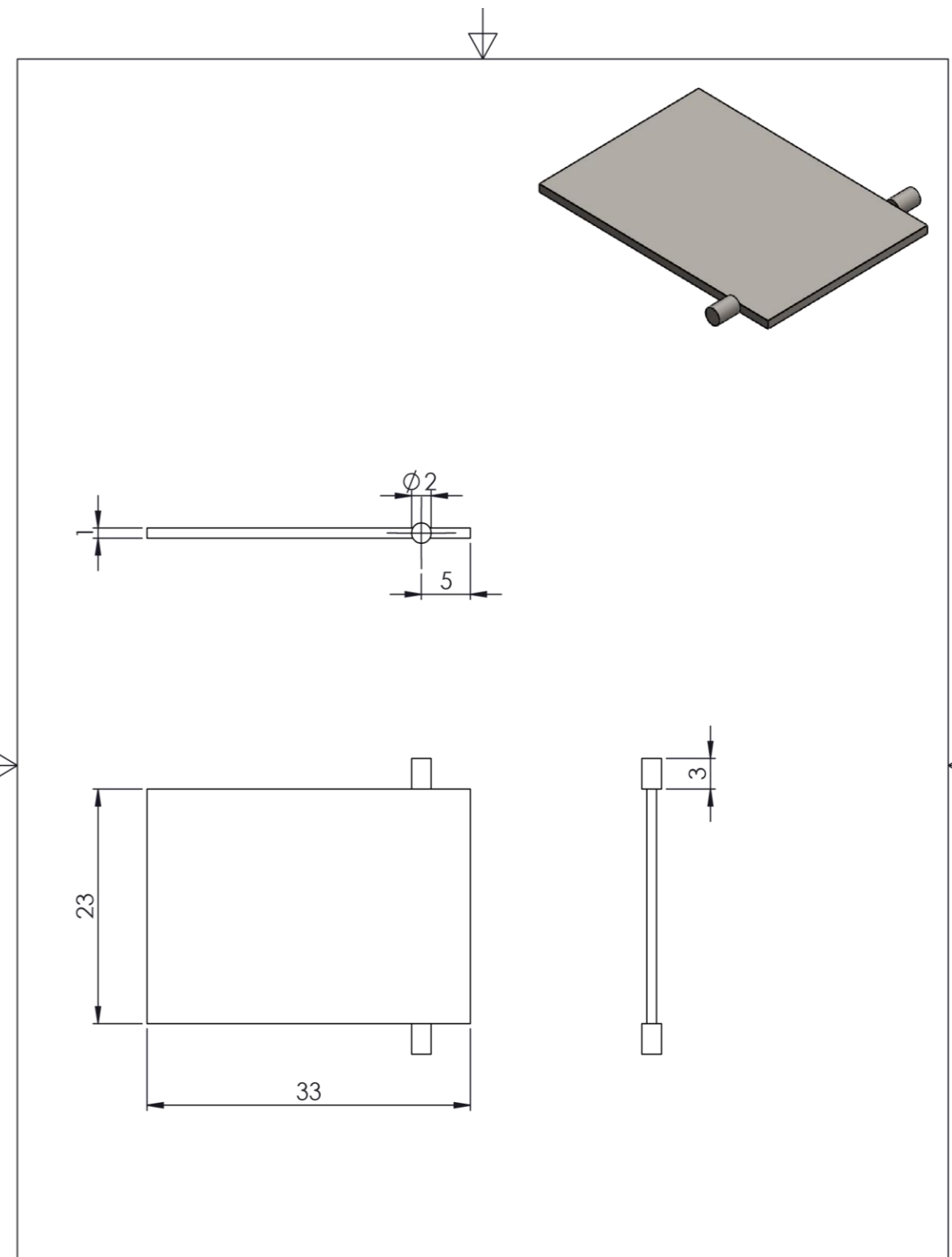

Opp. ruwheid (zie NEN 3634)	Maattoleranties NEN-ISO 2768-	MATERIAAL: Plain Carbon Steel	Vorm- en plaatstol. (zie NEN-ISO11010)
	SCHAAL: 2:1	GETEKEND: Iris Dirks & Chislain Huids	OPMERKING:
	MAATEENHEID: mm	AFDELING: IPO	
	DATUM: 9-4-2017	GEZIEN:	
			NUMMER: A4

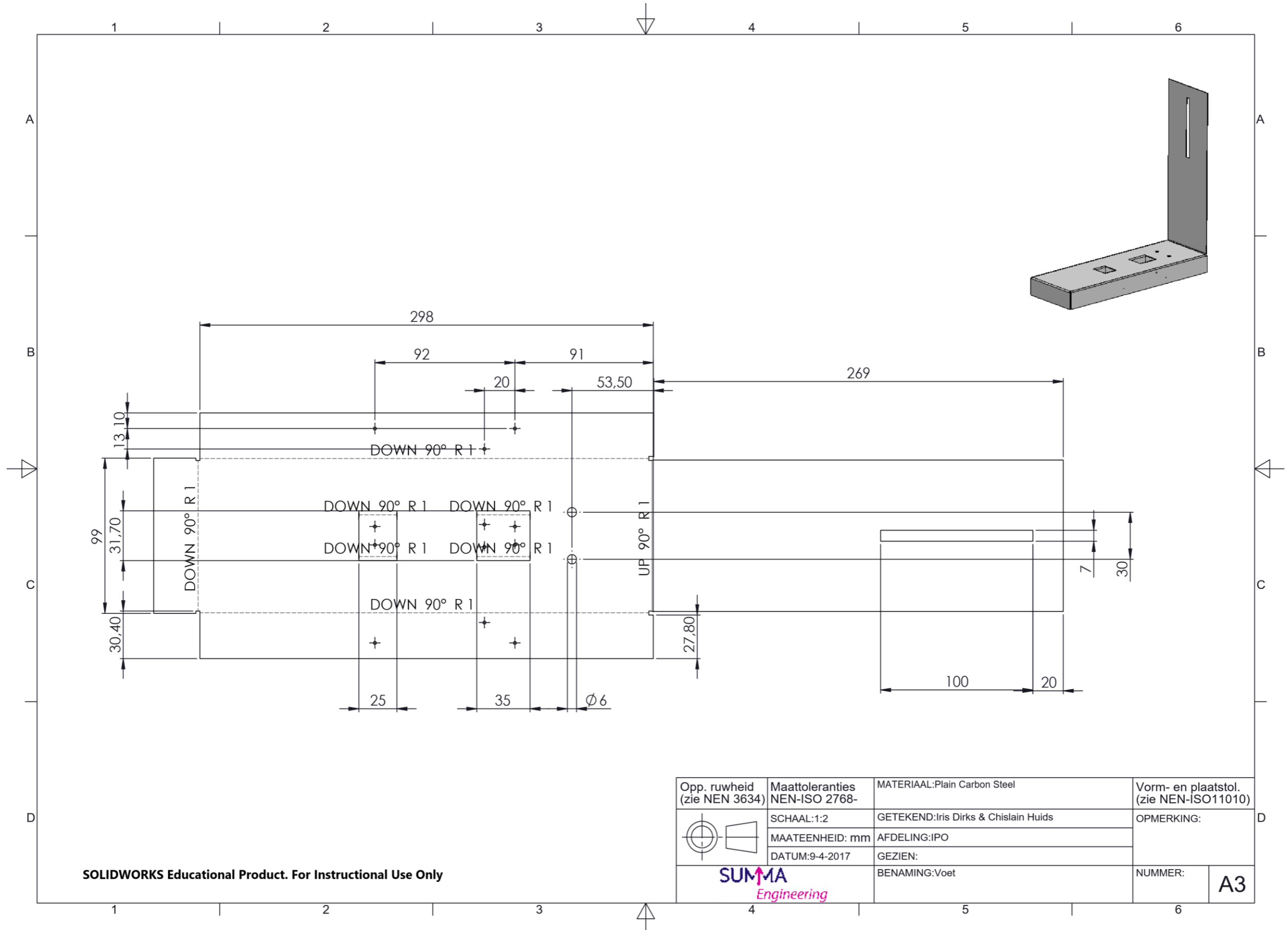

SOLIDWORKS Educational Product. For Instructional Use Only

Opp. ruwheid (zie NEN 3634)	Maattoleranties NEN-ISO 2768-	MATERIAAL: Plain Carbon Steel	Vorm- en plaatstol. (zie NEN-ISO11010)
	SCHAAL: 1:2	GETEKEND: Iris Dirks & Chislain Huids	OPMERKING:
	MAATEENHEID: mm	AFDELING: IPO	
	DATUM: 9-4-2017	GEZIEN:	
		BENAMING: Voet	NUMMER: A3

10. Prototype

